

Pyroelectric Infrared Radial Sensor

Model:D203S

PIR SENSOR CO., LTD

General-Purpose Dual Element Pyroelectric Infrared Radial Sensor

The pyroelectric infrared sensor detects infrared radiation on the basis of the characteristics that the polarization of pyroelectric material changes with temperature. Dual compensated sensing elements are applied to suppress the interference resulting from temperature variation. As a result, the operating stability of the sensor is greatly improved. Our products can be used in many applications. Such as in security systems, burglar alarms, visitor acknowledgement, light switch control and intellectualized toy, etc.

Standard Specifications and Dimensions

Recommended Model	D203S
Encapsulation Type	TO-5
IR Receiving Electrode	2×1mm, 2 elements
Window Size	4×3mm
Spectral Response	5-14μm
Transmittance	≥75%
Signal Output [Vp-p]	≥3500mV
Sensitivity	≥3300V/W
Detectivity (D*)	≥1.4 ×10 ⁸ cmHz ^{1/2} /W
Noise[Vp-p]	<70mV
Output Balance	<10%
Offset Voltage	0.3-1.2V
Supply Voltage	3-15V
Operating Temp.	-30-70°C
Storage Temp.	-40-80°C
Field of View Equivalent Circuit	
Equivalent Circuit	

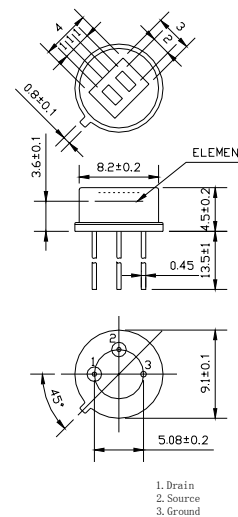

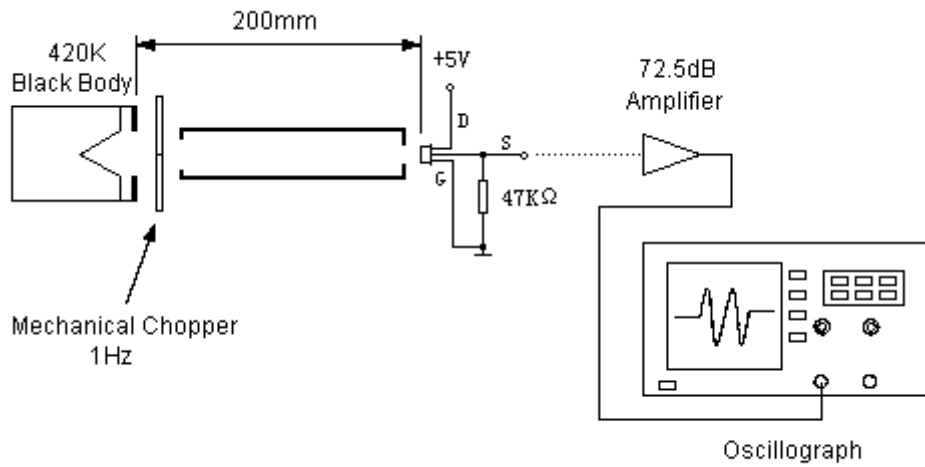
Test Method

Test conditions

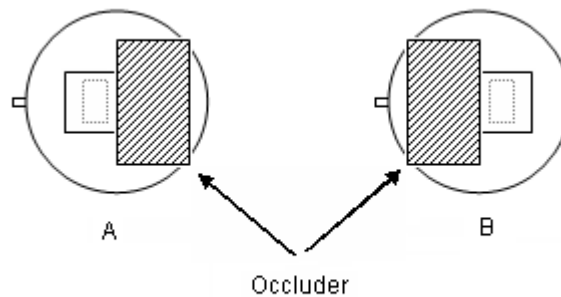
- ◆ Ambient temperature 25°C
- ◆ Black-body temperature 420K(147°C)
- ◆ Modulating frequency 1 Hz, 0.3-3.5Hz Δf ,
- ◆ 72.5 dB Amplifier



The sensitivity balance of dual element sensor is calculated through testing the sensitivity (single signal output voltage) of each element and using the following formula:

$$\text{Balance} = |V_A - V_B| / (V_A + V_B) \times 100\%$$

$$V_A = \text{Sensitivity of side A (mVp-p)}$$

$$V_B = \text{Sensitivity of side B (mVp-p)}$$

Typical Application

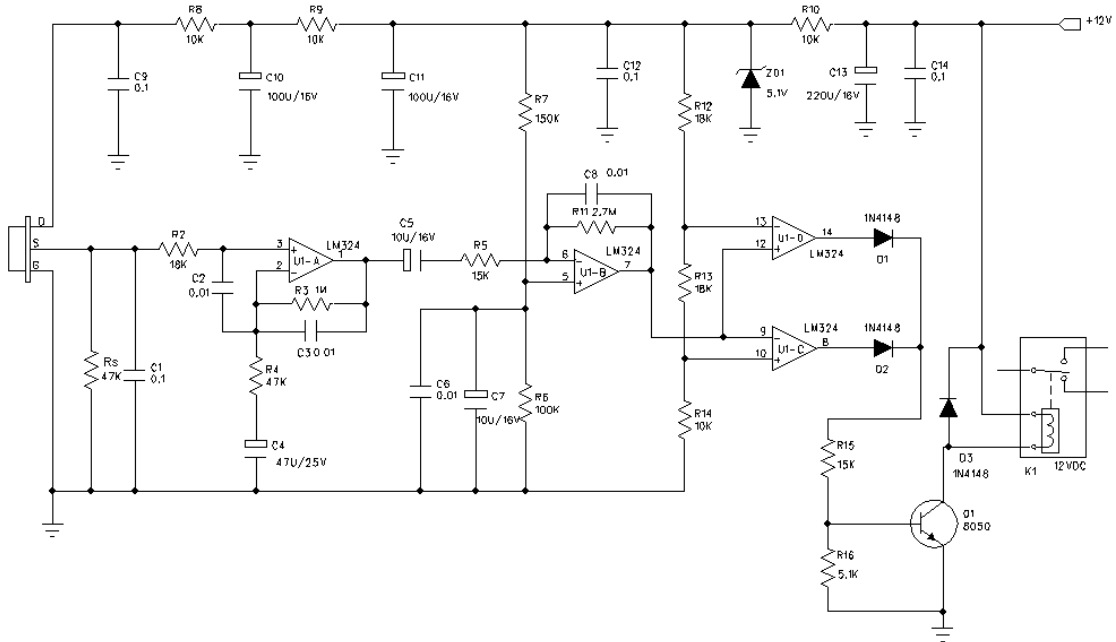

Notice:

U1A-D:LM324

Vdd:12V DC

Rs=47K Ω @ on an offset voltage

Spectral Response of Window Materials

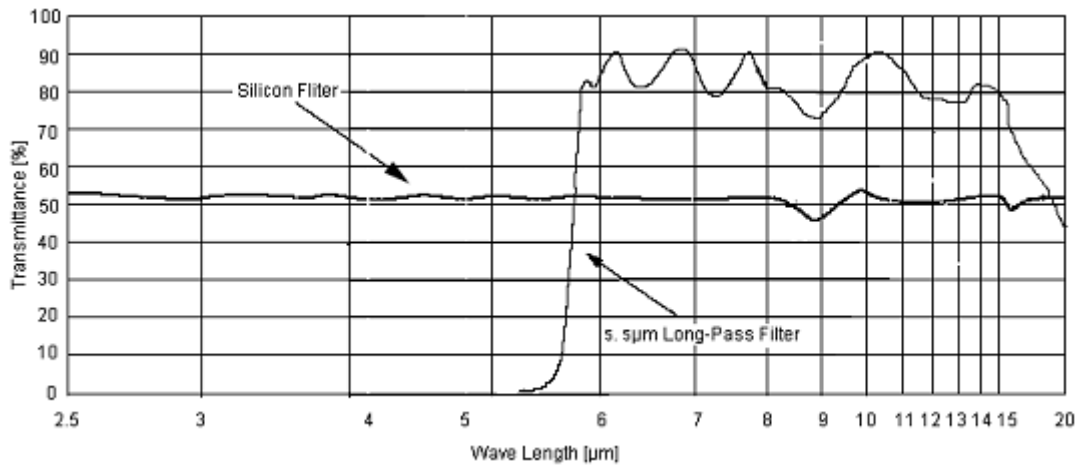

Notice:

The above curve is the typical figure of 5.5 μ m pass IR filter, the curve is the average value of IR transmittance, the window's substrate is vacuum-coated with semiconductor material.

■ Fresnel Lens for Human Body Detection

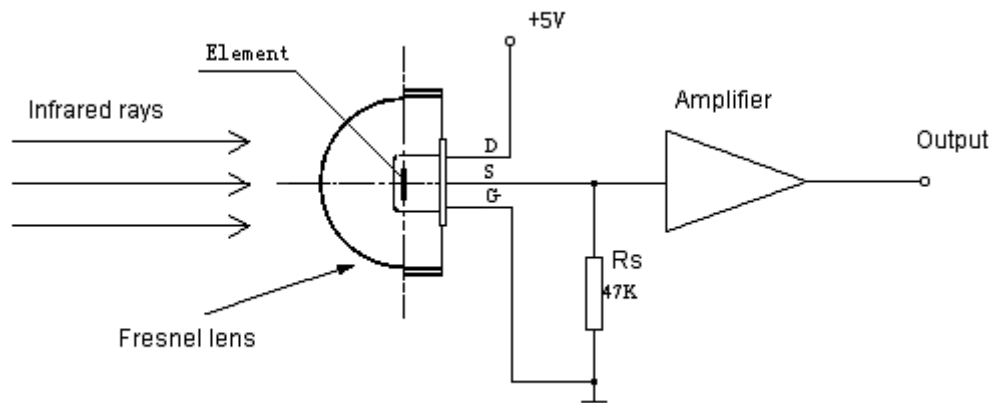
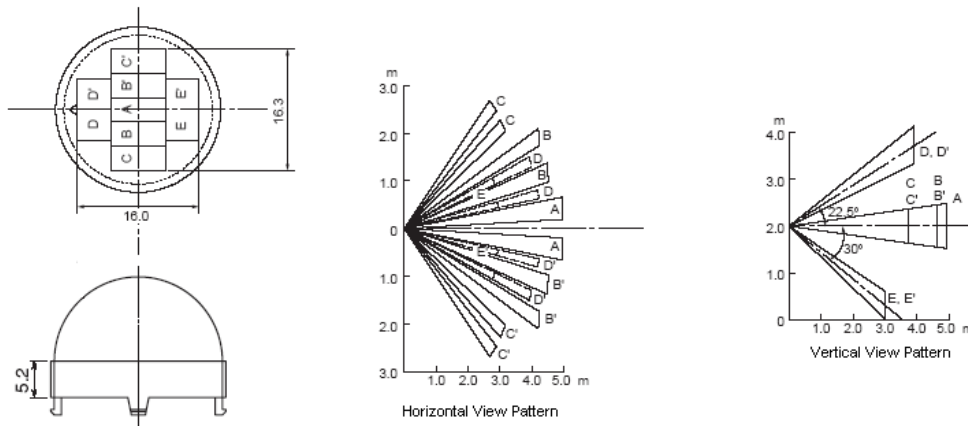

■ Directions for Use

- Pay attention to the mounting direction of the sensor's element and the size of element ichnography. Combining with focus of Fresnel lens can achieve a optimal optics design.
- The ex-factory parameter of sensor is gained by testing in the condition of standard Black Body and the relevant circuit after one minute steadying-time.
- The detecting distance of sensor is a multidimensional function, consisting of ambient temperature, temperature of moving target , target distance of Fresnel Lens', ambient humidity , amplifier gain and comparison voltage.
- The welding shall be made at 4mm above as per the recommendation for lead wire of sensor seat, and the welding should be completed in the shortest possible time.
- Do not touch the window by hand and the hard things directly.
- Strong shake and static should be avoided.
- This products are packed with the environmental protection material ,and the sensors' surface has been covered specially with OHK anti-erode material, 100pcs per small package ,3000pcs per large package.

